

May 13 & 14, 2022

Judge:

Tim Finkenbinder

Hunt
County
Horseman's
Association



Hunt County Horse Show

Trail CLASS # 1 - 3

Show Date: 2007

w w w . H o r s e S h o w P a t t e r n s . c o m

w w w . H o r s e S h o w P a t t e r n s . c o m

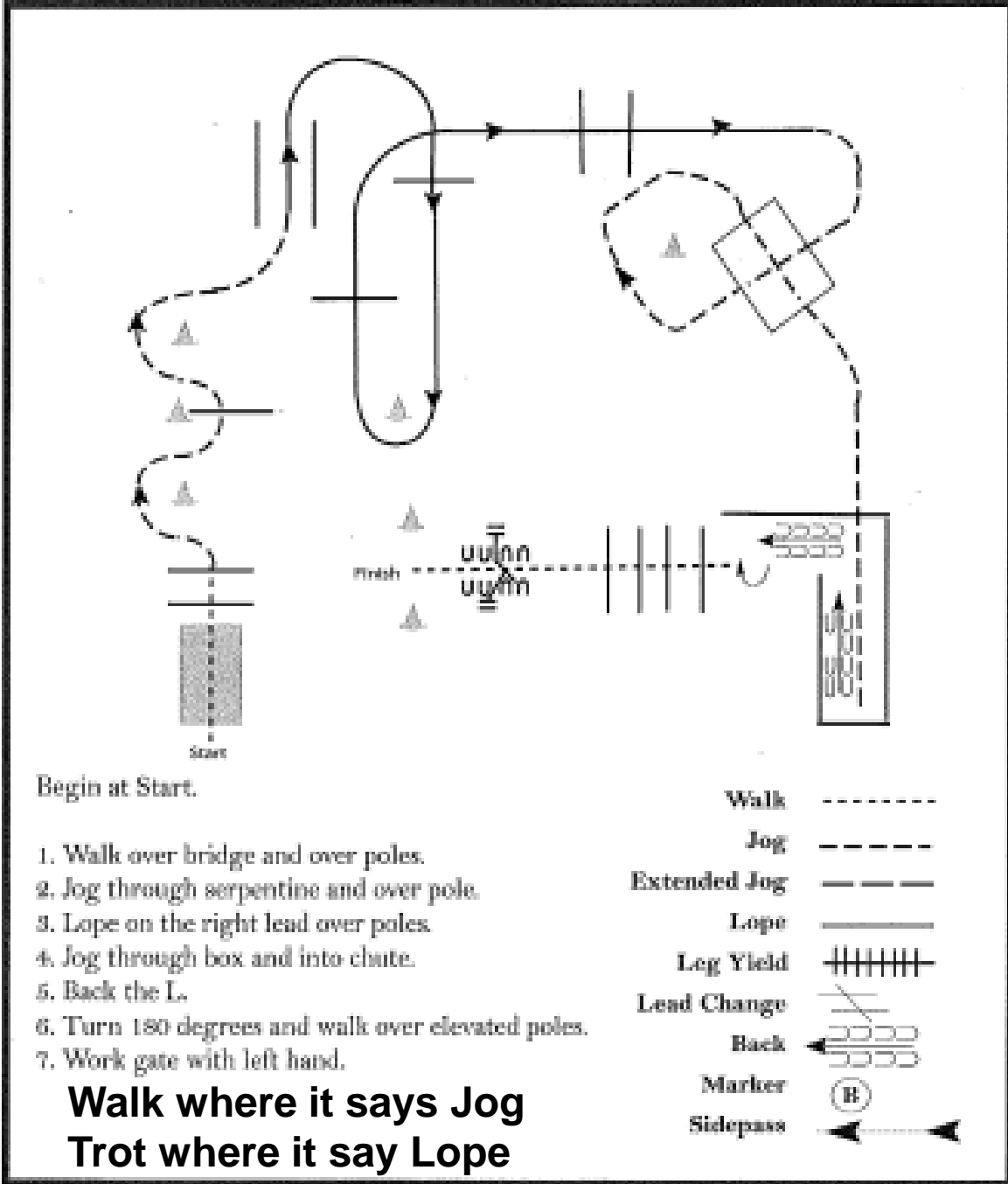

Begin at Start.

1. Walk over bridge and over poles.
2. Jog through serpentine and over pole.
3. Lope on the right lead over poles.
4. Jog through box and into chute.
5. Back the L.
6. Turn 180 degrees and walk over elevated poles.
7. Work gate with left hand.

Walk where it says Jog
Trot where it say Lope

Walk	-----
Jog	- - - - -
Extended Jog	-----
Lope	=====
Leg Yield	
Lead Change	↖ ↗
Back	←←←←←
Marker	⊙ B
Sidepass	←→

[T/2-7]

Pattern Provided by:
Trail - Level 2

Hunt County Horse Show

Trail CLASS # 4 - 8

Show Date: 2007

w w w . H o r s e S h o w P a t t e r n s . c o m

w w w . H o r s e S h o w P a t t e r n s . c o m

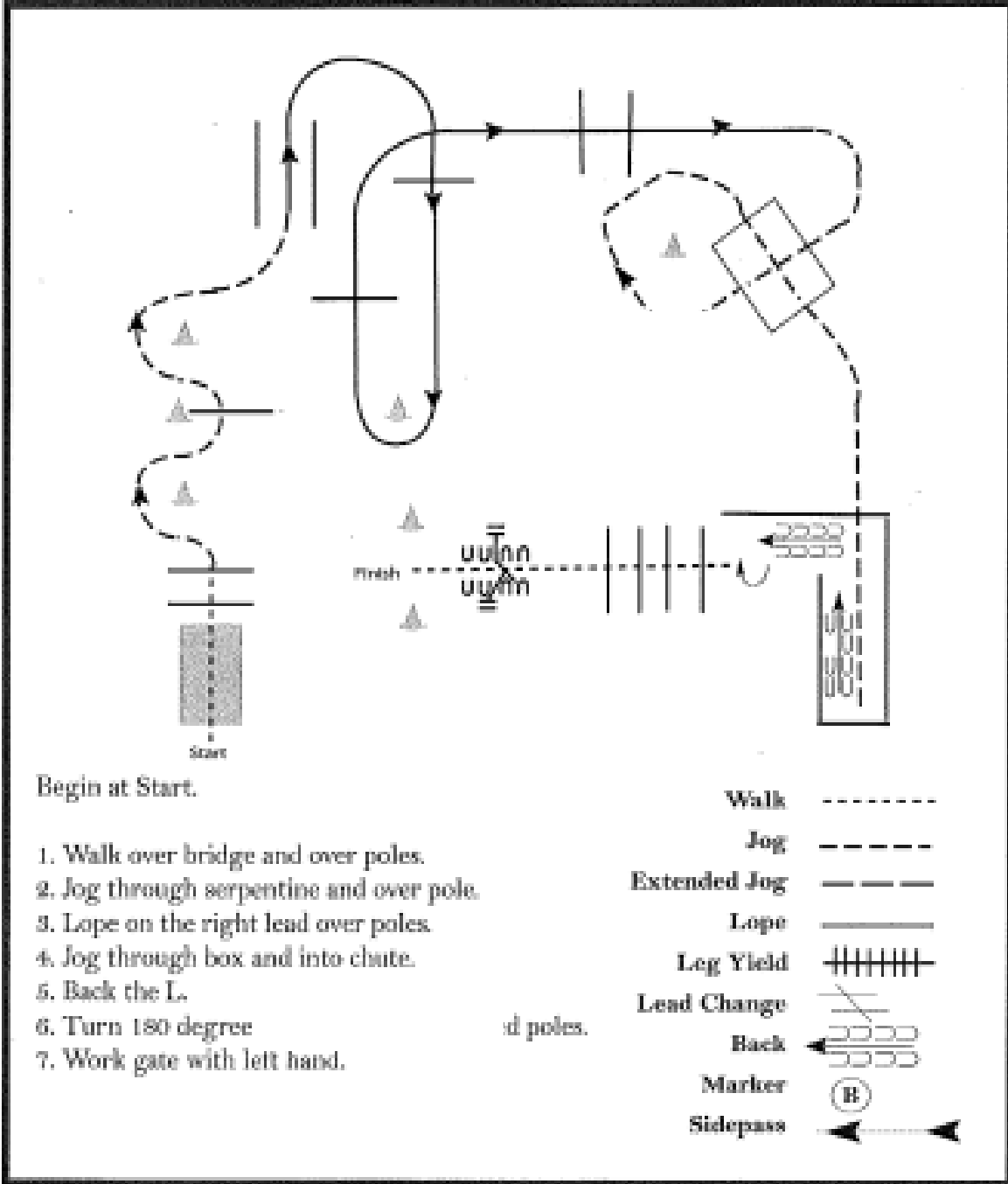

Begin at Start.

1. Walk over bridge and over poles.
2. Jog through serpentine and over pole.
3. Lope on the right lead over poles.
4. Jog through box and into chute.
5. Back the L.
6. Turn 180 degree
7. Work gate with left hand.

Walk	-----
Jog	- - - - -
Extended Jog	— — — — —
Lope	—————
Leg Yield	
Lead Change	///
Back	←←←←←
Marker	⊙ B
Sidepass	←→

Pattern Provided by:
Trail - Level 2

[T/2-7]

Ranch Trail

CLASS # 9

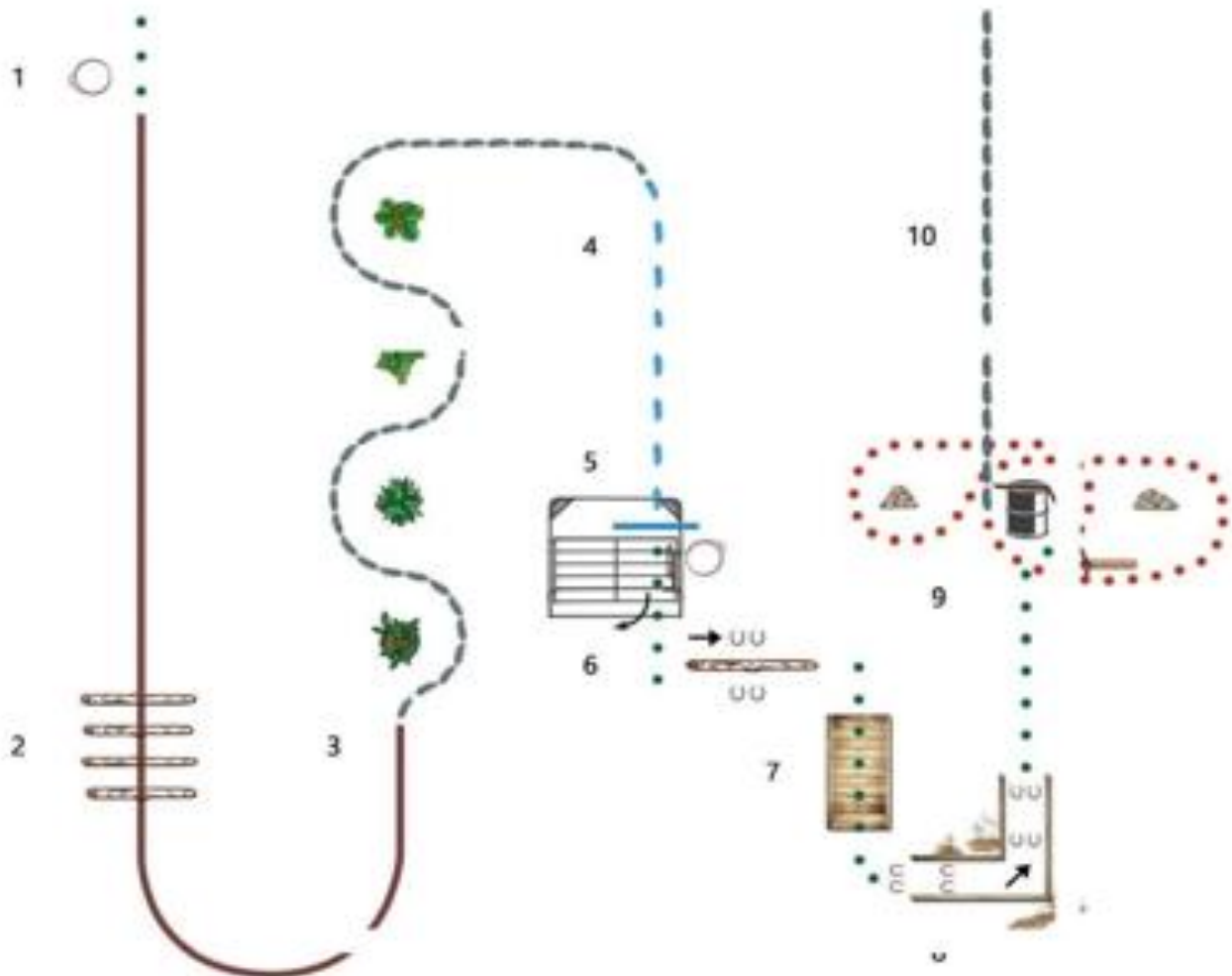

Course Description

1. Enter course at a Walk, Pick up Rope & Carry to Gate
2. Lope over logs
3. Break to Trot thru Serpentine
4. Extend Trot
5. Stop at Gate, Hang up Rope, Open Right-Hand Gate & Close
6. Side-Pass across Log
7. Walk across Bridge
8. Back thru "L" obstacle
9. Walk to obstacle & Drag Log in Figure-8, Return Rope
10. Exit course at a Trot

Legend

- | | |
|----------------|-----------|
| WALK | ••••• |
| WALK WITH DRAG | ••••• |
| TROT | - - - - - |
| EXTENDED TROT | - - - - - |
| LOPE | ————— |

CLASS # 10

RANCH RIDING WALK TROT

Pattern #1

WALK	—————
TROT	- - - - -
EXT TROT	· · · · ·

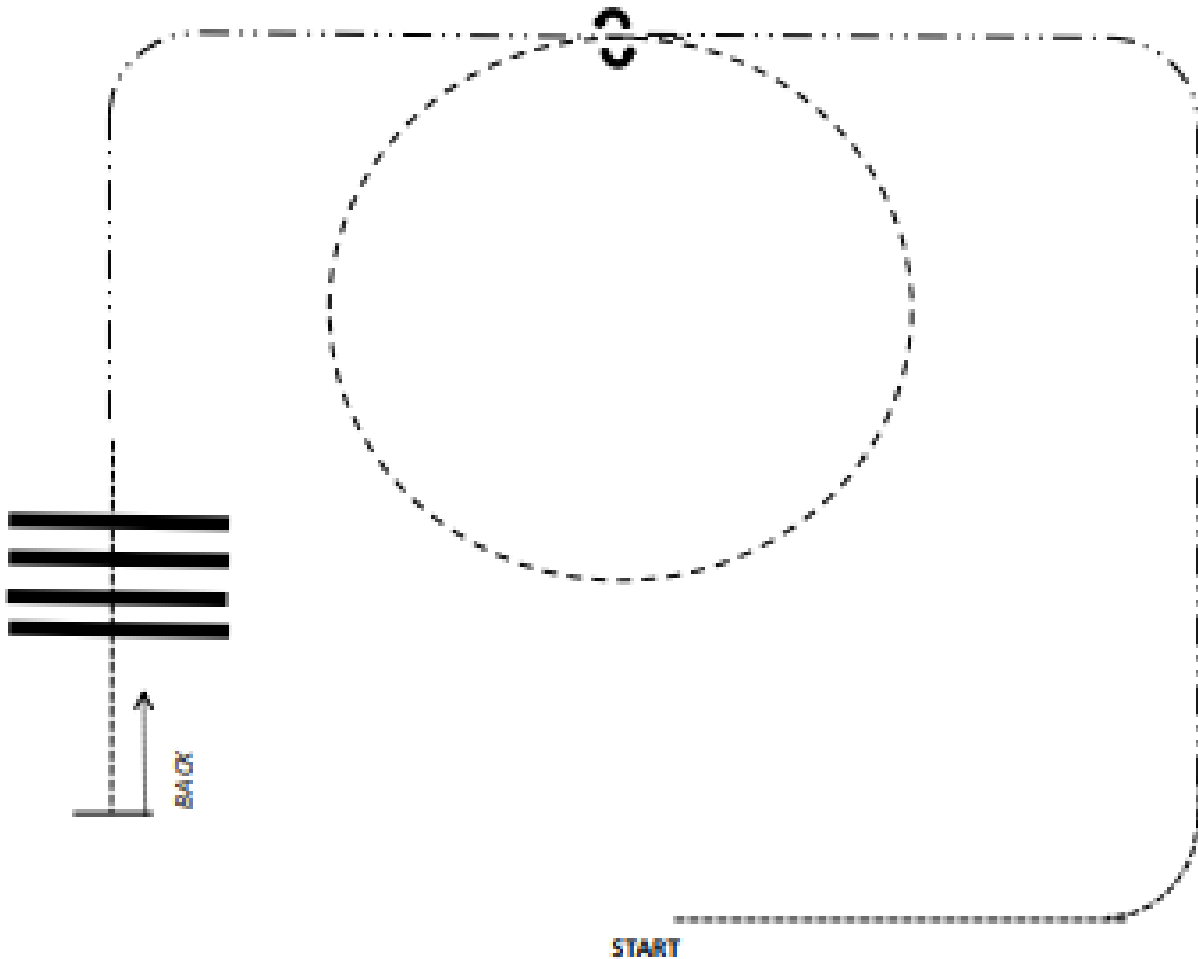

1. WALK
2. EXT. TROT 1/2 way up the ARENA
3. TURN LEFT EXT. TROT to Center of ARENA
4. TROT CIRCLE to LEFT
5. STOP / BACK 1 Horse Length
6. 360 TURN LEFT
7. EXT. TROT
8. WALK over RAILS
9. STOP / BACK 1 Horse Length

RANCH RIDING - PATTERN I

CLASS # 11 - 12

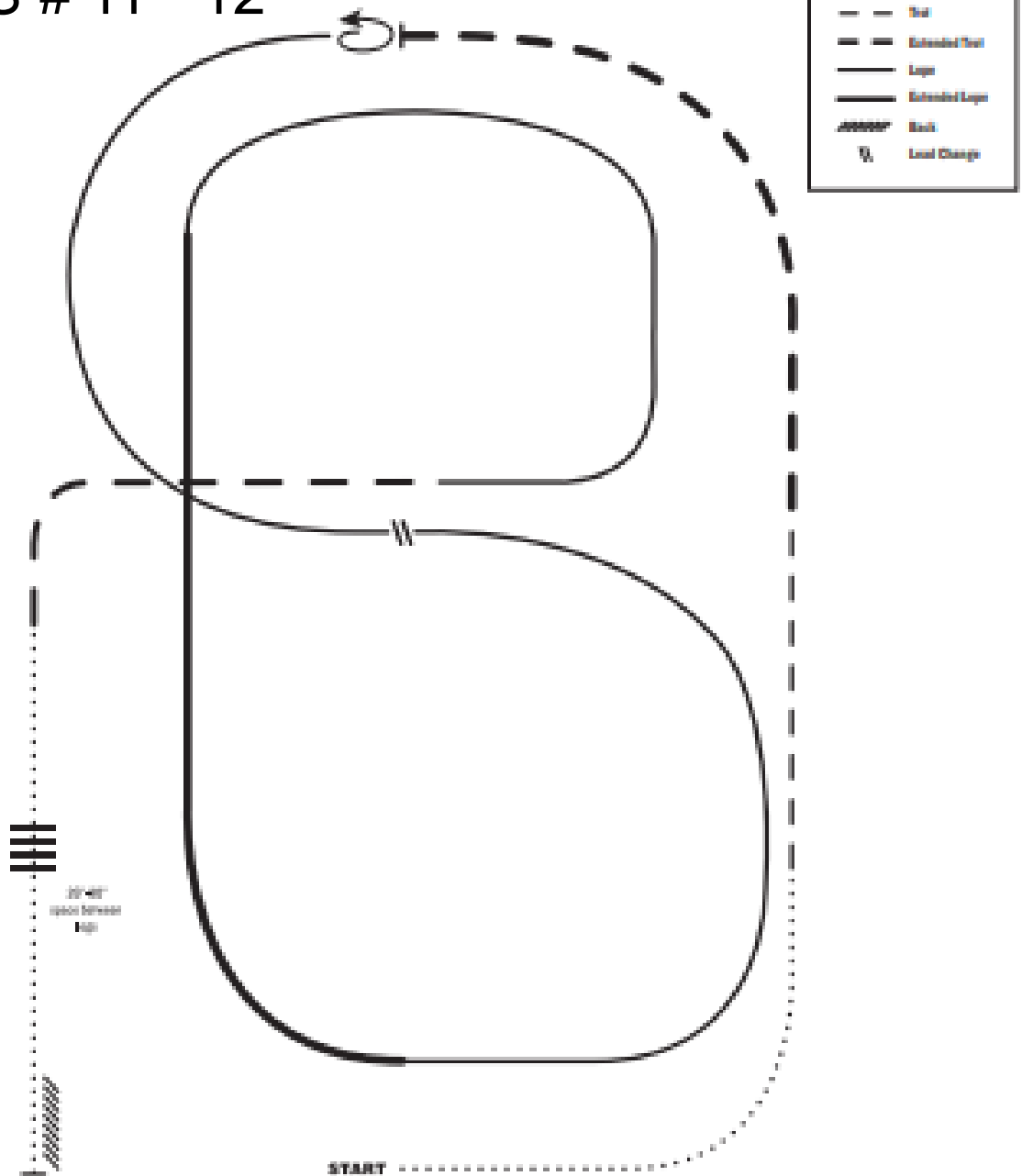

1. Walk
2. Trot
3. Extend the trot, at the top of the arena, stop
4. 360° turn left
5. Left lead (1/2 circle, lope to the center)
6. Change leads (simple or flying)
7. Right lead (1/2 circle)
8. Extended lope up the long side of the arena (right lead)
9. Collect back to a lope around the top of the arena and back to center
10. Break down to an extended trot
11. Walk over legs
12. Stop and back

Note: The above description of this pattern is only intended for the general depiction of the pattern. Exhibitors should utilize the arena space to best exhibit their horses.

RANCH RIDING - PATTERN 6

LEGEND

.....	Walk
- - - -	Extended Walk
- - - -	Trot
- - - -	Extended Trot
————	Lope
————	Extended Lope
	Back
↻	Lead Change

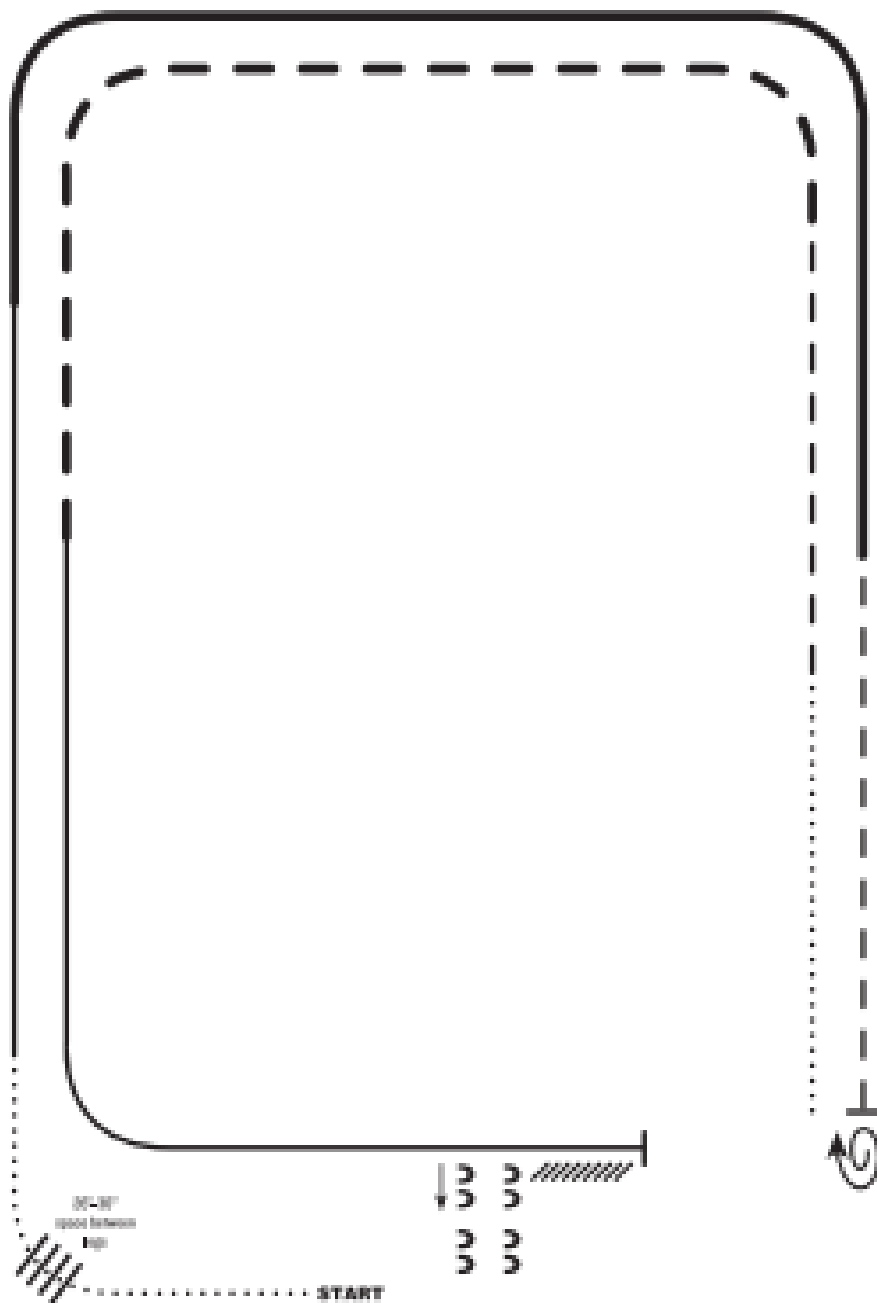

1. Walk
2. Walk over logs
3. Lope right lead
4. Extended lope right lead
5. Trot
6. Stop, 1 1/2 turn right
7. Walk
8. Trot
9. Extended trot
10. Lope left lead
11. Stop and back
12. Side pass right

CLASS # 13 - 15

Note: The above description of this pattern is only intended for the general depiction of the pattern. Exhibitors should utilize the arena space to best exhibit their horses.

SHOWMANSHIP

Small Fry

CLASS # 53 & 54

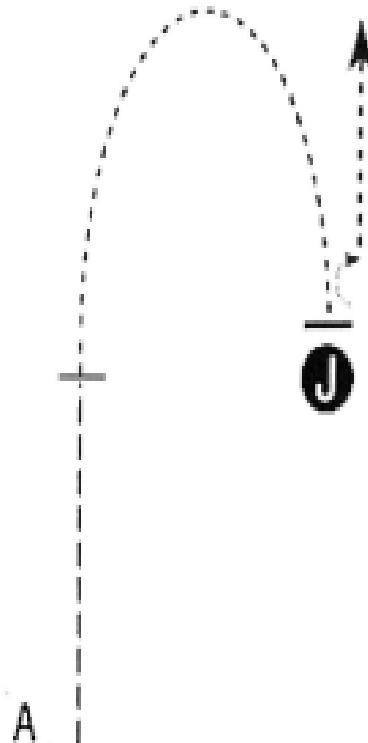

Be ready at A.

1. When acknowledged, trot until even with Judge.
2. Stop and pause briefly.
3. Walk in a half circle to Judge.
4. Stop and set up for inspection.
5. When dismissed, perform a 180 degree turn and walk straight away from judge.

Follow the instructions of your ring steward.



SHOWMANSHIP

Rookie and Level I (Novice) Amateur and Youth

CLASS # 56 & 57

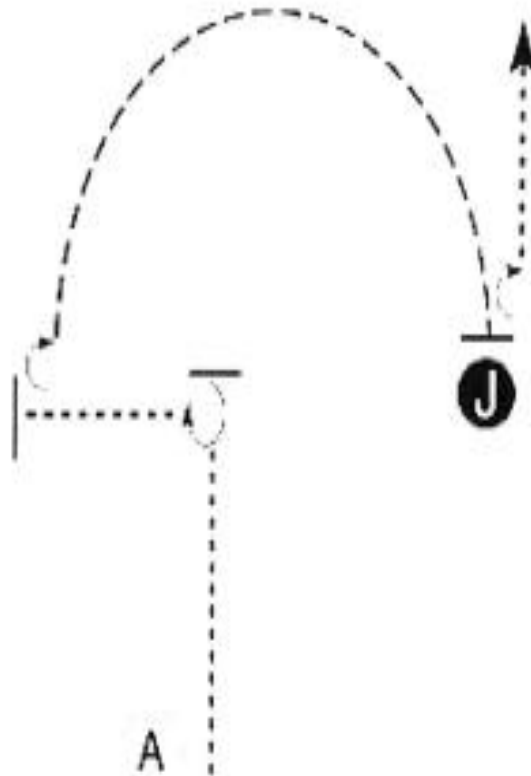

Be ready at A.

1. When acknowledged, walk until even with Judge.
2. Stop and perform a 270 degree turn.
3. Walk approximately two horse lengths.
4. Stop and perform a 90 degree turn.
5. Trot in a half circle to Judge.
6. Stop and set up for inspection.
7. When dismissed, perform a 180 degree turn and walk straight away from judge.

Walk	-----
Trot	- - - - -
Back	← ㄩ ㄩ ㄩ ㄩ ㄩ
Marker	B
Judge	ⓐ

Follow the instructions of your ring steward.

SHOWMANSHIP

Amateur, Amateur Select, Youth All Ages

CLASS # 55, 58 & 59

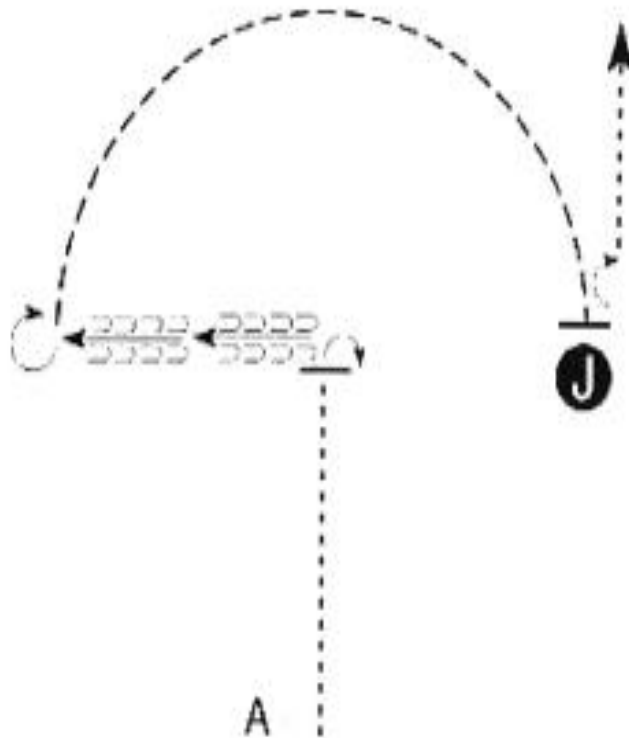

Be ready at A.

1. When acknowledged, walk until horse's hip is even with Judge.
2. Perform a 90 degree turn.
3. Back approximately two horse lengths.
4. Stop and perform a 270 degree turn.
5. Trot in a half circle to Judge
6. Stop and set up for inspection.
7. When dismissed, perform a 180 degree turn and walk straight away from judge.

Walk	-----
Trot	- - - - -
Back	← 
Marker	B
Judge	J

Follow the instructions of your ring steward.

EQUITATION

Small Fry CLASS # 73 & 74

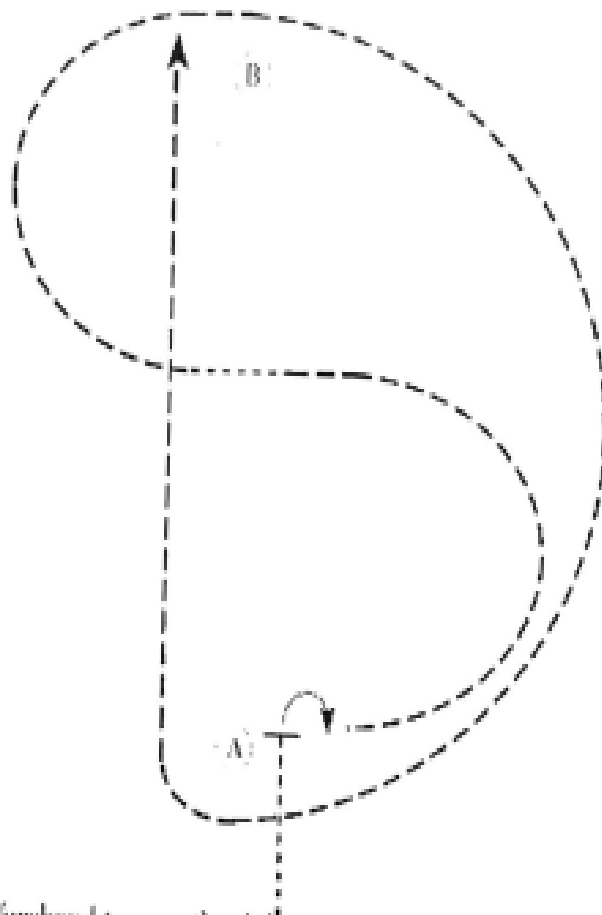

Be ready before A.

1. Walk to A.
2. Perform a 90 degree forehand turn to the right.
3. Trot on the right diagonal in a half circle to center of pattern.
4. Walk 2-3 horse lengths.
5. Sitting trot in a half circle to B.
6. Trot on the left diagonal to and around A.
7. Continue the trot on the left diagonal to B.

Pattern is over once you pass B.

Follow the instructions of your ring steward.

Walk
Trot	- - - - -
Extended Trot	— — — —
Canter	— — — —
Log Yield	
Lead Change	← →
Back	← ← ← ←
Marker (B)	○
Sidepass	↖ ↗
Hard Gallop	— — — —

EQUITATION

Rookie and Level I (Novice) Amateur and Youth

CLASS # 75 & 76

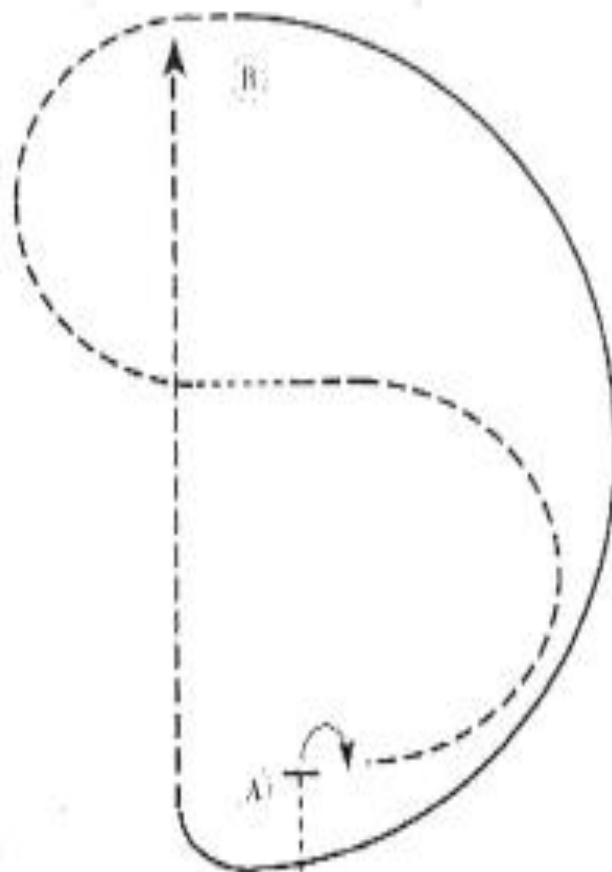

Be ready before A.

1. Walk to A.
2. Perform a 90 degree forehand turn to the right.
3. Trot on the right diagonal in a half circle to center of pattern.
4. Walk 2-3 horse lengths.
5. Siding trot in a half circle to B.
6. Canter on the right lead to and around A.
7. Trot on the left diagonal to B.

Pattern is over once you pass B.

Follow the instructions of your ring steward.

Walk
Trot	-----
Extended Trot	-----
Canter	-----
Log Yield	
Lead Change
Back	←←←←
Marker	B
Sidepass	← ←
Hand Gallop	-----

EQUITATION

Amateur, Amateur Select, Youth All Ages

CLASS # 77 & 78

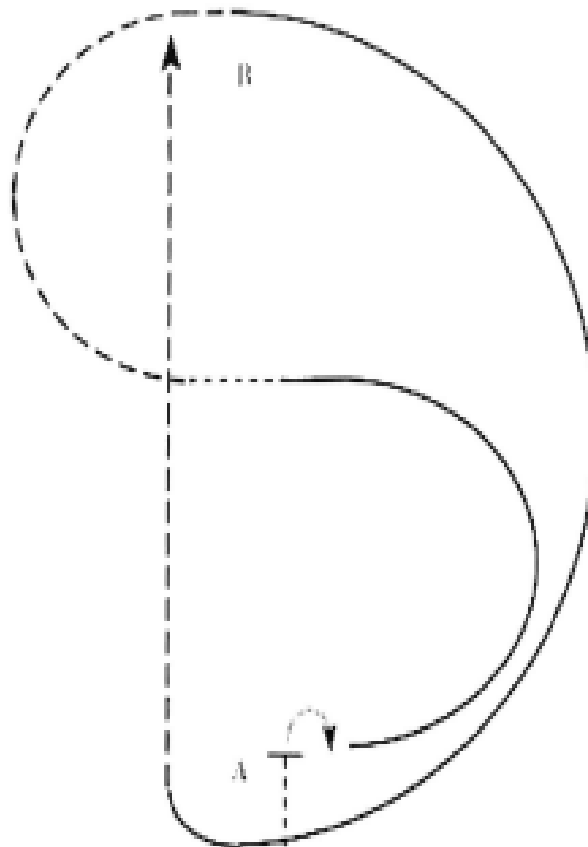

Be ready before A.

1. Walk to A.
2. Perform a 90 degree forehand turn to the right.
3. Canter on the left lead in a half circle to center of pattern.
4. Walk 2-3 horse lengths.
5. Sitting trot in a half circle to B.
6. Canter on the right lead to and around A.
7. Trot on the left diagonal to B.

Pattern is over once you pass B.

Follow the instructions of your ring steward.

Walk
Trot	-----
Extended Trot	-----
Canter	—————
Leg Yield	
Lead Change	↕
Back	← 10 20 30
Marker	
Sidepass	← ←
Hand Gallop	—————

HORSEMANSHIP

Small Fry / walk trot

CLASS # 89 & 90

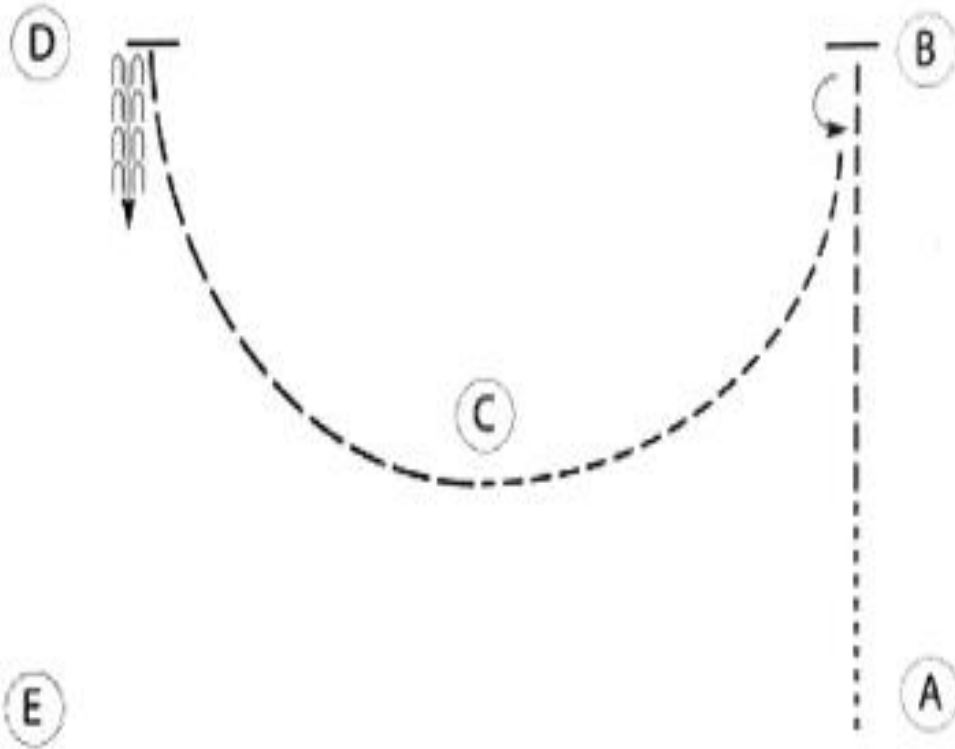

Be ready at A.

1. Walk approximately two strides from A.
2. Jog to B.
3. Stop and perform a 180 degree turn to the left.
4. Jog a half circle to C.
5. Extend the jog to D.
6. Stop at D and back approximately one horse length.

Walk	-----
Jog	- - - - -
Extended Jog	— — —
Lope	—————
Leg Yield	
Lead Change	⌘
Back	← ㄩ ㄩ ㄩ ㄩ
Marker	ⓑ
Sidepass	← ←

Follow the instructions of your ring steward.

HORSEMANSHIP

Rookie and Level I (Novice) Amateur and Youth

CLASS # 91 & 92

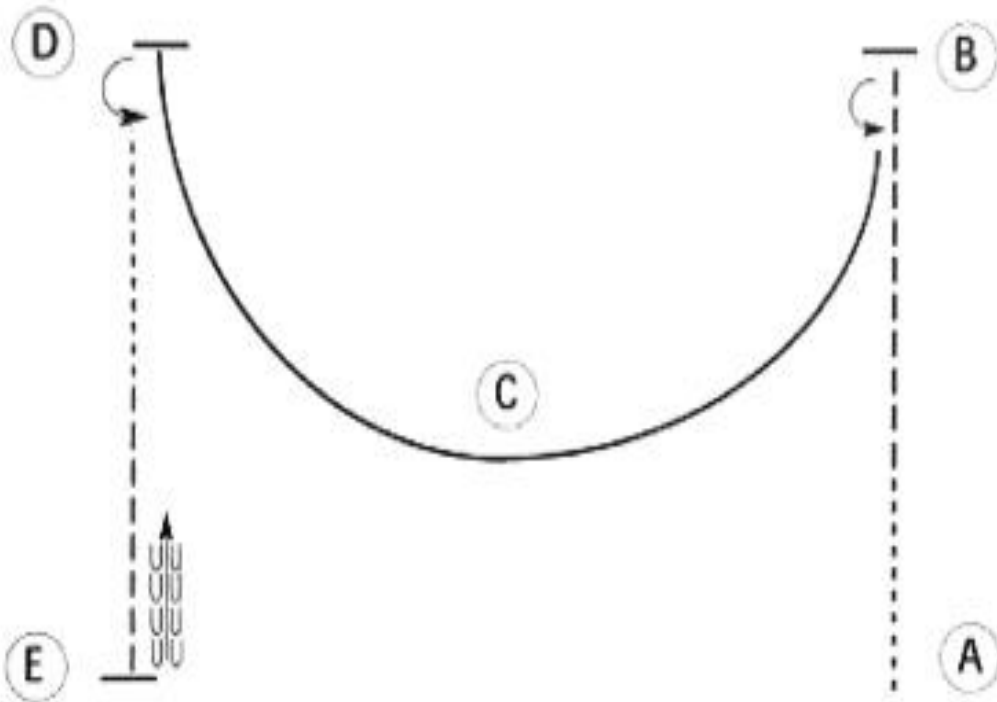

Be ready at A.

1. Walk approximately two strides from A.
2. Jog to B.
3. Stop and perform a 180 degree turn to the left.
4. Lope on the right lead around C and to D.
5. Stop and perform a 180 degree turn to the left.
6. Walk halfway to E.
7. Jog to E, stop and back approximately one horse length.

Follow the instructions of your ring steward.

Walk	-----
Jog	-----
Extended Jog	-----
Lope	-----
Leg Yield	
Lead Change	↙
Back	← ○○○ ○○○
Marker	ⓑ
Sidepass	←→

HORSEMANSHIP

Amateur, Amateur Select, Youth All Ages

CLASS # 93 & 94

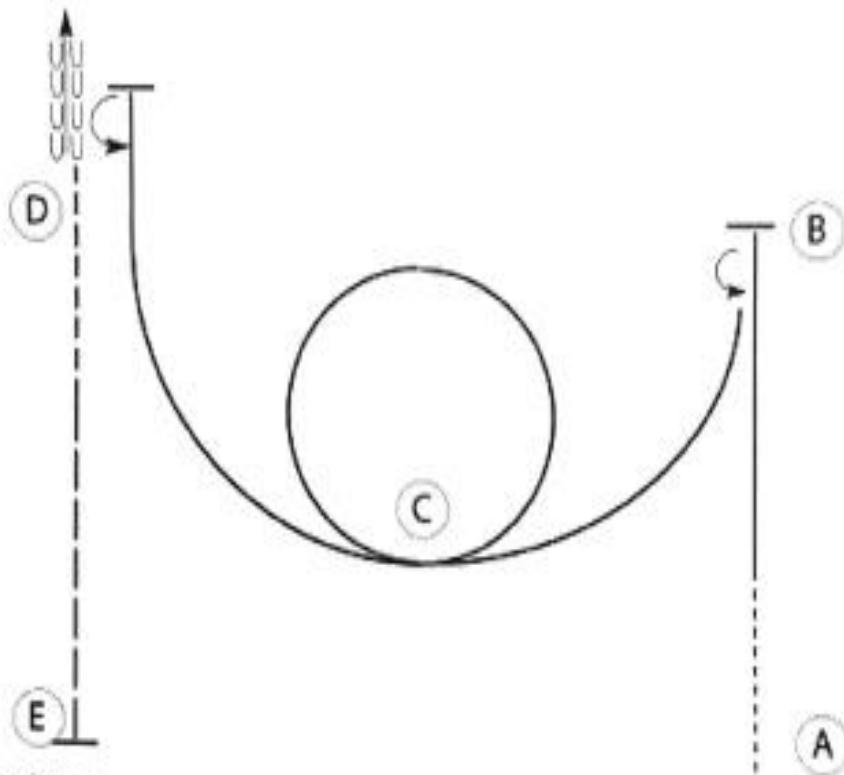

Be ready at A.

1. Walk approximately two strides from A.
2. Lope on the left lead to B.
3. Stop and perform a 180 degree turn to the left.
4. Lope on the right lead to C.
5. Lope a circle with speed around C.
6. Slow to a lope and lope past D.
7. Perform a 180 degree turn to the left.
8. Back approximately one horse length.
9. Jog halfway to E.
10. Extend the jog to E.
11. Stop at E.

Follow the instructions of your ring steward.

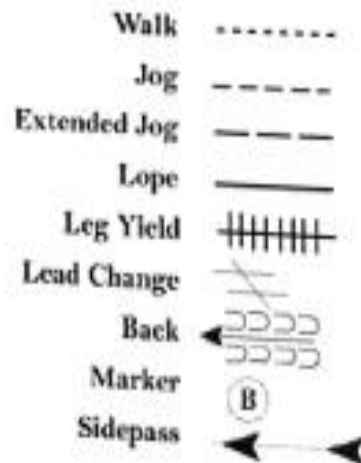

WESTERN RIDING PATTERN 2

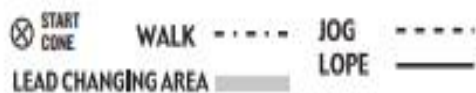
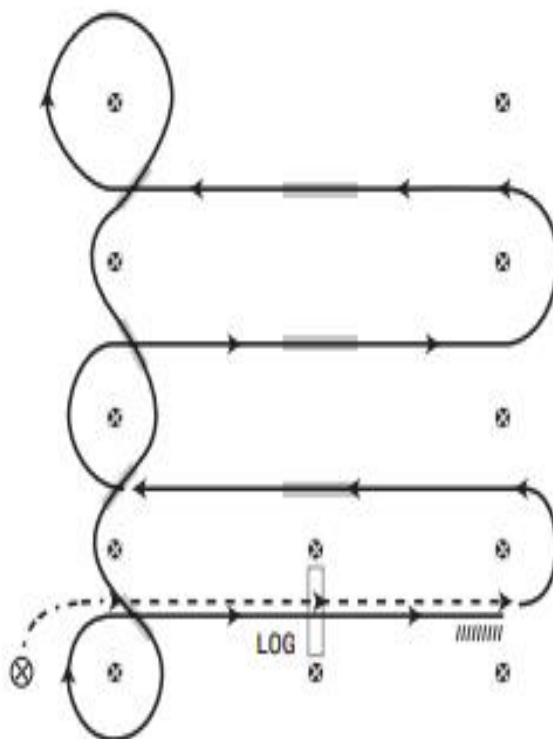

CLASS # 95 - 97

1. Walk, transition to jog, jog over log
2. Transition to the lope, on the left lead
3. First crossing change
4. Second crossing change
5. Third crossing change
6. Circle & first line change
7. Second line change
8. Third line change
9. Fourth line change & circle
10. Lope over log
11. Lope, stop & back